



特徴 Feature

- 錠前は操作性に優れた防塵シャッター付新型リバーシブルキーTAK60を標準装備(A-51-TAK60)
- 左右兼用型
- The lock comes standard with the TAK60, a new-style reversible key with an easy-to-use dustproof shutter.
- (A-51-TAK60)
- For both left-hand and right-hand use.

仕様	● 材質: 亜鉛合金 (ZDC) ● 表面仕上: クロムめっき (MZCr) ● 最大適用板厚: A-51-1-1/5.5mm A-51-2-1/1.5mm
用途	● 付属品: 大ナット・ビスセット・キー2本
納期	● キュービクル・制御盤
備考	● 標準在庫品 ● 鍵違いも製作します。 ● 特別な表面処理はご相談ください。 ● 本製品の止め金取付け用ねじは、緩み防止のため「緩み防止剤」の塗布をお奨めします。
Specifications	● Material: Zinc alloy (ZDC) ● Finish: Chrome plating (MZCr) ● Max. applicable panel thickness: A-51-1-1: 5.5mm A-51-2-1: 1.5mm
Specific use	● Accessories: Large nut, screws, two keys
Remarks	● Cubicles and control boards ● It is recommended that thread-locking fluid be used to prevent loosening of the mounting screws for the catch.



A-51-1-1-TAK60



キーNo.TAK60  
Key



キーNo.0200  
Key



A-51-2-1-TAK60

[A-51-1-1]

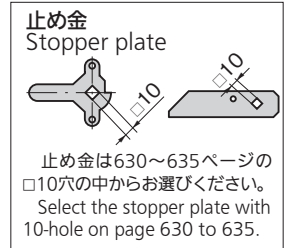
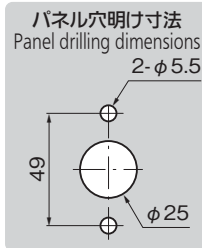
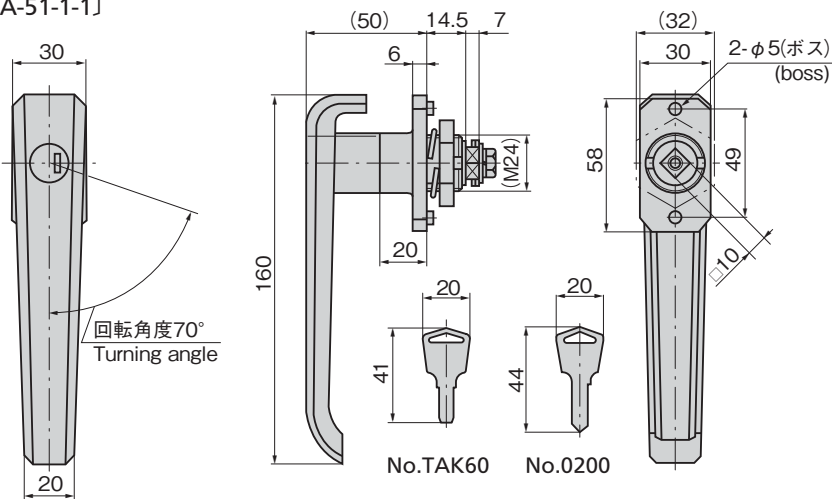

[A-51-2-1]

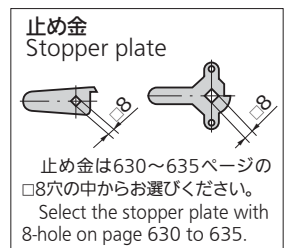
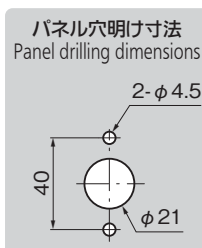
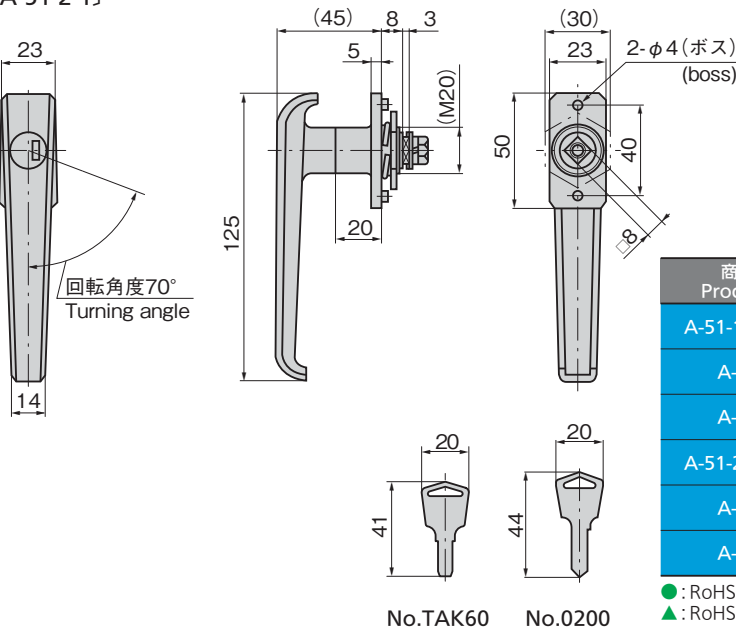

商品番号 Product No.	RoHS 10	鍵番号 Key No.	製品質量(g) Mass	コード Code	単価	量販価格 数量	単価
A-51-1-1-TAK60	●	TAK60	370	04019			
A-51-1-1	●	0200		00173			
A-51-1-2	●	鍵なし Without lock		00174			
A-51-2-1-TAK60	●	TAK60	200	04020			
A-51-2-1	●	0200		00175			
A-51-2-2	●	鍵なし Without lock		00176			

●: RoHS10指令対応品  
▲: RoHS10指令に対応可能です。  
※大量のご注文は更にお安くなります。