

B-2078 チタン製

B-1078 ステンレス製

B-1078-BR ステンレス製



B-1078-5



B-1078-13-BR

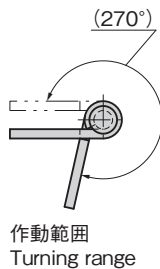
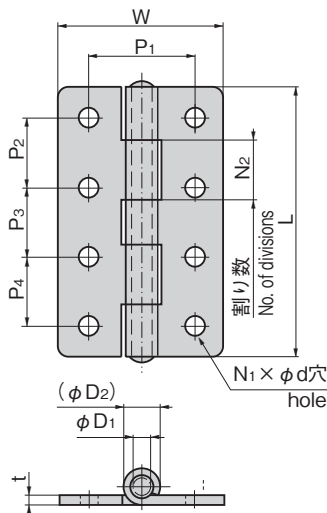

特徴 Feature

- チタン製・ステンレス製で耐食性に優れています。
- Corrosion-resistant stainless steel/titanium is used.

仕様

[B-2078]	●材 質：純チタン2種 ●表面仕上：ビーズショット処理
[B-1078 B-1078-BR]	●材 質：ステンレス鋼板(SUS304) ●表面仕上：鏡面バフ研磨(B-1078) バレル研磨(B-1078-BR)
用途	●船舶・車両・厨房機器・屋外用機器
納期	●標準在庫品(B-1078/B-1078-BR)
備考	●穴なし(B-1078-1~6、B-1078-1~6-BR) ●穴あき(B-2078-11~16、B-1078-11~16、B-1078-11~16-BR) ●鉄製はB-41(686ページ)をご使用ください。 ●チタン製B-2078-1~6は中止品になりました。

Specifications

[B-2078]	●Material: Pure titanium grade 2 ●Finish: Beading process
[B-1078 B-1078-BR]	●Material: Stainless steel plate (SUS304) ●Finish: Mirror surface buffing (B-1078) Barrel polishing (B-1078-BR)
Specific use	●Ships, vehicles, kitchen and outdoor equipment
Remarks	●Without hole (B-1078-1 to 6, B-1078-1 to 6-BR) ●With hole (B-2078-11 to 16, B-1078-11 to 16, B-1078-11 to 16-BR) ●For iron-made, use B-41 on page 686. ●Titanium B-2078-1 through 6 are no longer manufactured.

長蝶番

平蝶番

裏蝶番

抜差し蝶番

フリーザーヒンジ

特装車蝶番

クリーンヒンジ

特殊蝶番

トルクヒンジ

ステー

その他のB製品

商品番号 Product No.	備考 Remarks	RoHS 10	L	W	t	P1	P2	P3	P4	φd	φD1	φ(D2)	N1	N2	参考値(2個使用) Reference values (Using 2 pieces)		製品質量(g) Mass	コード Code	
															扉高×扉幅 Door height× door width	扉質量(kg) Door mass			
B-2078-11	穴あき With hole	●	40	35	1.5	22	26	/	/	3.2	3	6.3	4	3	600×300	4.5	13	12911	
B-2078-12		●	50	35	1.5	22	34	/	/	4.3	3	6.3	4	3	600×300	7	16	12912	
B-2078-13		●	65	50	2	30	23	23	/	/	4.3	4	8.8	6	5	600×300	20	41	12913
B-2078-14		●	75	50	2	30	27	27	/	/	5.3	4	8.8	6	5	600×300	21	45	12914
B-2078-15		●	90	60	3	38	35	35	/	/	6.4	6	12.3	6	5	600×300	56	105	12915
B-2078-16		●	100	60	3	38	26	26	26	26	6.4	6	12.3	8	5	1200×600	30	110	12916
B-1078-1	穴なし Without hole	●	40	35	1.5	/	/	/	/	3	6.3	/	3	3	600×300	7.1	25	10681	
B-1078-2		●	50	35	1.5	/	/	/	/	3	6.3	/	3	3	800×400	8	30	10682	
B-1078-3		●	65	50	2	/	/	/	/	4.5	8.8	/	5	5	1200×600	15	70	10683	
B-1078-4		●	75	50	2	/	/	/	/	4.5	8.8	/	5	5	1200×600	16	85	10684	
B-1078-5		●	90	60	3	/	/	/	/	6	12.3	/	5	5	1600×800	32	190	10685	
B-1078-6		●	100	60	3	/	/	/	/	6	12.3	/	5	5	1600×800	35	200	10686	
B-1078-11	穴あき With hole	●	40	35	1.5	22	26	/	/	3.2	3	6.3	4	3	600×300	7.1	25	10687	
B-1078-12		●	50	35	1.5	22	34	/	/	4.3	3	6.3	4	3	800×400	8	30	10688	
B-1078-13		●	65	50	2	30	23	23	/	/	4.3	4.5	8.8	6	5	1200×600	15	70	10689
B-1078-14		●	75	50	2	30	27	27	/	/	5.3	4.5	8.8	6	5	1200×600	16	85	10690
B-1078-15		●	90	60	3	38	35	35	/	/	6.4	6	12.3	6	5	1600×800	32	180	10691
B-1078-16		●	100	60	3	38	26	26	26	26	6.4	6	12.3	8	5	1600×800	35	195	10692
B-1078-1-BR	穴なし Without hole	●	40	35	1.5	/	/	/	/	3	6.3	/	3	3	600×300	7.1	25	13527	
B-1078-2-BR		●	50	35	1.5	/	/	/	/	3	6.3	/	3	3	800×400	8	30	13528	
B-1078-3-BR		●	65	50	2	/	/	/	/	4.5	8.8	/	5	5	1200×600	15	70	13529	
B-1078-4-BR		●	75	50	2	/	/	/	/	4.5	8.8	/	5	5	1200×600	16	85	13530	
B-1078-5-BR		●	90	60	3	/	/	/	/	6	12.3	/	5	5	1600×800	32	190	13531	
B-1078-6-BR		●	100	60	3	/	/	/	/	6	12.3	/	5	5	1600×800	35	200	13532	
B-1078-11-BR	穴あき With hole	●	40	35	1.5	22	26	/	/	3.2	3	6.3	4	3	600×300	7.1	25	13533	
B-1078-12-BR		●	50	35	1.5	22	34	/	/	4.3	3	6.3	4	3	800×400	8	30	13534	
B-1078-13-BR		●	65	50	2	30	23	23	/	/	4.3	4.5	8.8	6	5	1200×600	15	70	13535
B-1078-14-BR		●	75	50	2	30	27	27	/	/	5.3	4.5	8.8	6	5	1200×600	16	85	13536
B-1078-15-BR		●	90	60	3	38	35	35	/	/	6.4	6	12.3	6	5	1600×800	32	180	13537
B-1078-16-BR		●	100	60	3	38	26	26	26	26	6.4	6	12.3	8	5	1600×800	35	195	13538

●: RoHS10指令対応品 ▲: RoHS10指令に対応可能です。