

RoHS 10 SUS ステンレス 錠穴付パチン錠 SNAP FASTENERS WITH KEYHOLES

C-1012 ステンレス製 C-12 黄銅製

特徴 Feature

- ステンレス製で耐食性に優れています。(C-1012)
- 南京錠で施錠ができます。(錠穴付き)
- レバーのガタつきを抑えるコイルばねを内蔵。
- Corrosion-resistant stainless steel is used.(C-1012)
- Can be locked with a padlock. (with key hole)
- Incorporated spring prevents lever from rattling.

- 用途 ● 計測機器・制御盤・工作機械・分電盤
 納期 ● 標準在庫品
 備考 ● 南京錠C-555は1315ページをご参照ください。

- Specific-use ● Measuring equipment, control and distribution boards and machine tools
 Remarks ● For padlock C-555, see page 1315.



C-1012-1-1

C-1012-1-2

C-12-2-1

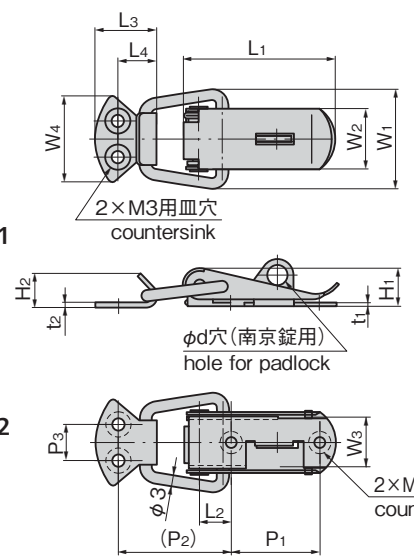

※本図は縮代0mmの場合です。
 C-12-1-1・C-1012-1-1を基準に作図しています。
 ※Drawings show the tightening margin of 0mm.
 Drawings are based on C-12-1-1 and C-1012-1-1.

商品番号 Product No.	RoHS 10	材質 Material	表面仕上 Finish	備考 Remarks	L1	L2	L3	L4	W1	W2	W3	W4	H1	H2	t1	t2	P1	(P2)	P3	φd	製品質量(g) Mass	コード Code
C-1012-1-1	●	冷間圧延 ステンレス 鋼板 (SUS304) Cold rolled stainless steel plate	バレル 研磨 Barrel polishing	錠穴付き With keyhole	53	8.5	18	11	32	21	15	28	13	9	1.5	1.5	34	32	12	5.5	37	20793
C-1012-1-2	●			錠穴なし Without keyhole	53	8.5	18	11	32	21	15	28	13	9	1.5	1.5	34	32	12	/	37	20794
C-1012-2-1	●			錠穴付き With keyhole	40	8	16	10	26	16	13	23	10	9	1.0	1.2	23	30	10	5	18	20795
C-1012-2-2	●			錠穴なし Without keyhole	40	8	16	10	26	16	13	23	10	9	1.0	1.2	23	30	10	/	18	20796
C-12-1-1	●	黄銅板 (C2801P) Brass plate	クロム めっき (MBCr) Chrome plating	錠穴付き With keyhole	53	9	18.5	11.5	33	21	15	28	13	9	1.5	1.5	34	32	12	5	41	20025
C-12-1-2	●			錠穴なし Without keyhole	53	9	18.5	11.5	33	21	15	28	13	9	1.5	1.5	34	32	12	/	41	20026
C-12-2-1	●			錠穴付き With keyhole	40	8	16	9.5	27.5	16	13	24	9	9	1.0	1.2	23	29	10	5	20	20027
C-12-2-2	●			錠穴なし Without keyhole	40	8	16	9.5	27.5	16	13	24	9	9	1.0	1.2	23	29	10	/	20	20028

● : RoHS10指令対応品 ▲ : RoHS10指令に対応可能です。